

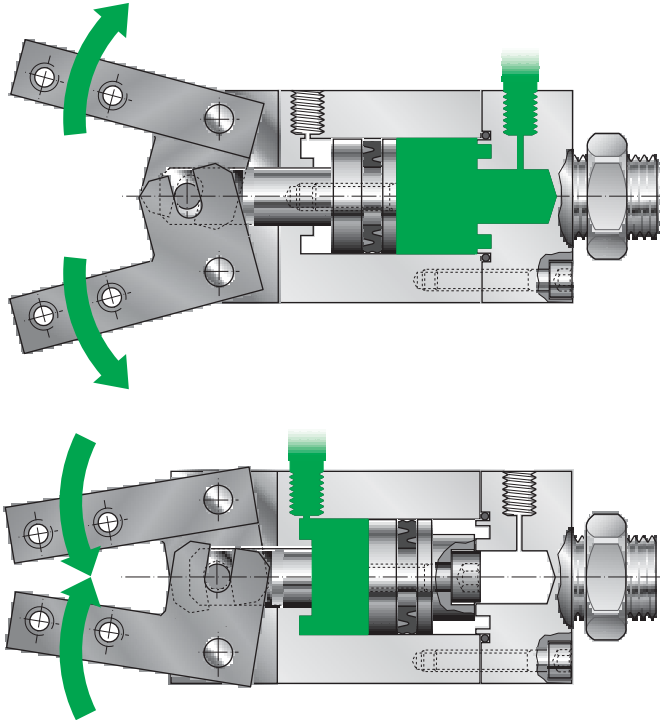

SERIE **MH** - **MHM**

PNEUMATIC GRIPPERS SERIES MANI DI PRESA A COMANDO PNEUMATICO SERIE



MH pneumatic grippers are available in single and double effect versions for bores 16-20-32-50. The magnetic version (**MHM**) is available starting from bore 20. Gripping force from 4 Kg. to 60 Kg. at 6 bar.

Le unità di presa Vesta serie **MH** a semplice e doppio effetto sono prodotte nei 4 alesaggi 16-20-32-50, magnetiche a partire dal diametro 20 (**MHM**). La forza di bloccaggio va da 4 a 60 Kg. a 6 bar. E' disponibile anche una versione a stelo posteriore uscente.

GRIPPERS CODE SERIE **MH** / CODICE DI IDENTIFICAZIONE DELLE MANI DI PRESA SERIE **MH**

Base / Base	MH <input type="checkbox"/> - <input type="checkbox"/> - <input type="checkbox"/> <input type="checkbox"/>	NA Normally open <i>Normalmente aperta</i>
M Magnetic <i>Predisposto per interruttori magnetici</i>	Bore Alesaggio (mm):	NC Normally closed <i>Normalmente chiusa</i>
	Ø16 16	SE - <input type="checkbox"/> <input type="checkbox"/>
	Ø20 20	Simple effect <i>Semplice effetto</i>
	Ø32 32	DE - <input type="checkbox"/>
	Ø50 50	Double effect <i>Doppio effetto</i>
		0 Base <i>Base</i>
		1 Back through rod <i>Stelo posteriore uscente</i>

For Ø16 no version M (Magnetic); for Ø50 no versions SE NA (Simple effect normally open) and SE NC (Double effect normally closed).
Per Ø16 la versione M (Magnetico) non è prevista; per Ø50 le versioni SE NA ed SE NC non sono previste.

TECHNICAL FEATURES

Body	Aluminium alloy.
Seals	Pre-lubricated lip seals.
Lubrication	Not required.
Medium	Filtered air.

Fingers and trunnions	Carbonium steel
Environment temperature range	-20 °C ÷ +80 °C
Bore	Ø16 ÷ Ø50
Max operating pressure	10 bar

CARATTERISTICHE TECNICHE

Corpo	Lega di alluminio.
Guarnizioni	Con profilo del labbro antiusura prelubrificato con grasso tipo "Long-Time".
Lubrificazione	Non necessaria.
Fluido	Aria filtrata.

Dita di presa e perni	Acciaio al carbonio
Temperatura ambiente	-20 °C ÷ +80 °C
Alesaggi	Ø16 ÷ Ø50
Pressione max d'esercizio	10 bar

GRIPPER Ø16
UNITA' DI PRESA Ø16

MH 16

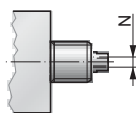
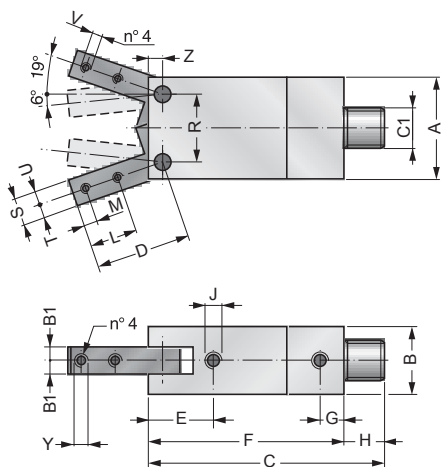

Through rod version
Versione stelo passante

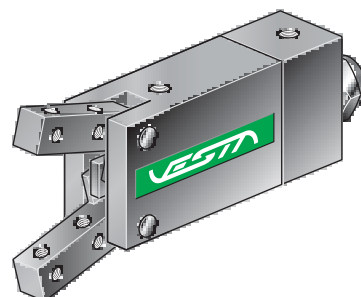
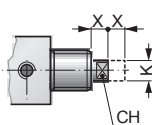

A	B	B1	C	ØC1	CH	D	E	F	G	H	ØJ	ØK	L	M	ØN	R	S	T	U	ØV	X	ØY	Z
30	20	3,95	68,7	M12x1,25	5	28	21,2	56,7	7	12	M5x0,8	6	14	4	M3x0,5 (8mm)	20	8	4,5	3,5	M3x0,5	5	M4x0,7	6,2

Weight / Peso : 125 g

6 bar gripping force at 15 mm. from fingers fulcrum:
Forze di bloccaggio a 6 bar a 15 mm di distanza dal fulcro delle dita:

MH 16 DE	6,5 Kg opening / in apertura	5,5 Kg closing / in chiusura
MH 16 SE NC	5,2 Kg opening / in apertura	
MH 16 SE NA	4 Kg closing / in chiusura	

GRIPPER Ø20
UNITA' DI PRESA Ø20

MH 20

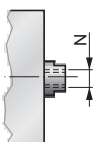
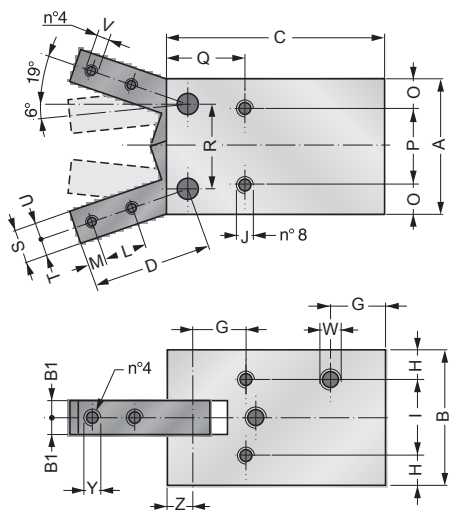

Through rod version
Versione stelo passante

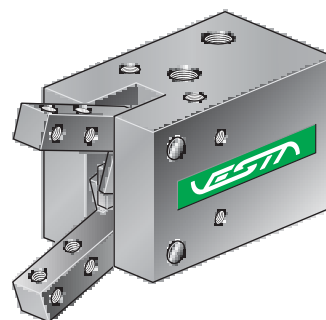
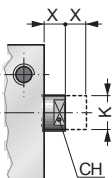

A	B	B1	C	CH	D	G	H	I	ØJ	ØK	L	M	ØN	O	P	Q	R	S	T	U	ØV	X	ØY	Z	W
32	32	3,95	53,5	6	28	13,5	7	18	M4x0,7	8	10	4	M4x0,7 (8mm)	7	18	19,7	20	8	4,5	3,5	M3x0,5	5	M4x0,7	6,2	M5x0,8

Weight / Peso : 175 g

6 bar gripping force at 15 mm. from fingers fulcrum:
Forze di bloccaggio a 6 bar a 15 mm di distanza dal fulcro delle dita:

MH 20 DE	12 Kg opening / in apertura	10 Kg closing / in chiusura
MH 20 SE NC	8,5 Kg opening / in apertura	
MH 20 SE NA	7,5 Kg closing / in chiusura	



MH 32

GRIPPER Ø32
UNITA' DI PRESA Ø32

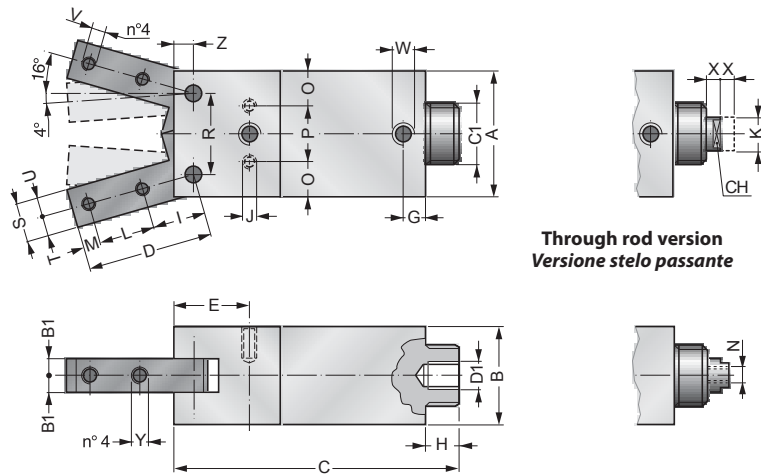
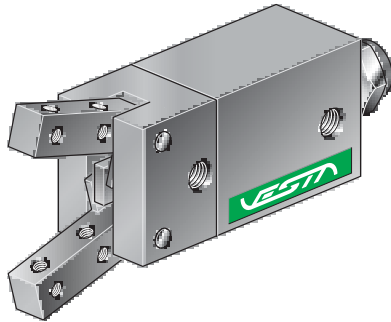

Through rod version
Versione stelo passante

A	B	B1	C	ØC1	CH	D	ØD1	E	G	H	ØJ	ØK	I	L	M	ØN	O	P	R	S	T	U	ØV	ØW	X	ØY	Z
45	35	5,95	105,2	M22x1,5	10	45	M10x1,25	30,2	8	12	M5x0,8	12	19	20	6	M5x0,8 (10mm)	12,5	20	28	14	8	6	M5x0,8	G1/8"	5	M6x1	10,2

Weight / Peso : 490 g

6 bar gripping
force at 15 mm. from fingers fulcrum:
Forze di bloccaggio a 6 bar
a 15 mm di distanza dal fulcro delle dita:

MH 32 DE	24 Kg opening / in apertura	22 Kg closing / in chiusura
MH 32 SE NC	19,5 Kg opening / in apertura	
MH 32 SE NA	16,5 Kg closing / in chiusura	

MHM 16

GRIPPER Ø16
UNITA' DI PRESA Ø16

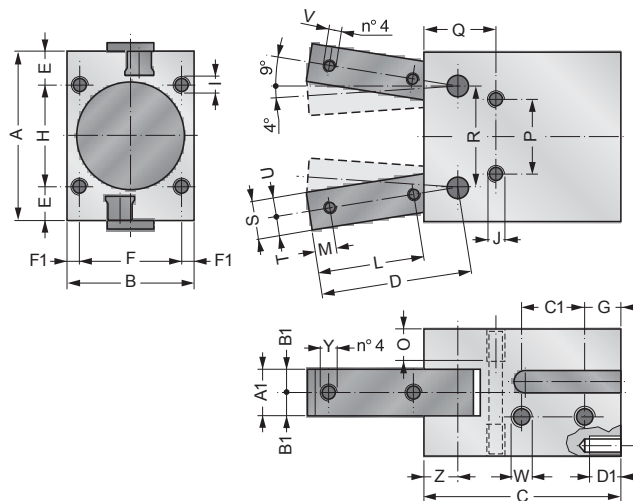
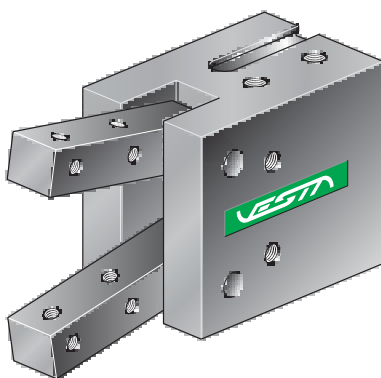

A	A1	B	B1	C	C1	D	D1	E	F	F1	G	H	ØI	ØJ	L	M	O	P	Q	R	S	T	U	ØV	ØW	ØY	Z
30	7,9	20	4	57	19	28	8	4	12	4	13	22	M4x0,7	M4x0,7	14	4	7	17	18	20	8	4,5	3,5	M3x0,5	M5x0,8	M4x0,7	6,2

Weight / Peso : 125 g

6 bar gripping
force at 15 mm. from fingers fulcrum:
Forze di bloccaggio a 6 bar
a 15 mm di distanza dal fulcro delle dita:

MHM 16 DE	6,5 Kg opening / in apertura	5,5 Kg closing / in chiusura
MHM 16 SE NC	5,2 Kg opening / in apertura	
MHM 16 SE NA	4 Kg closing / in chiusura	

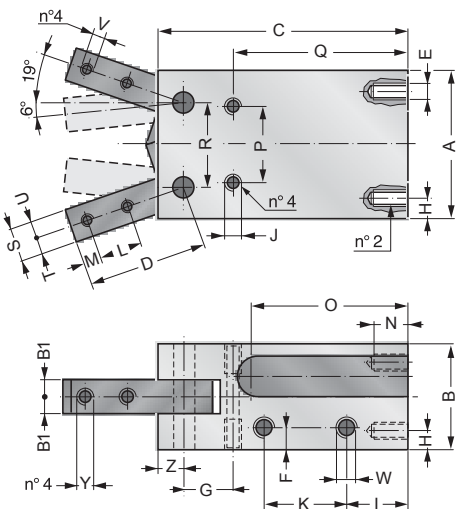

MAGNETIC GRIPPER Ø20
UNITA' MAGNETICA Ø20

MHM 20

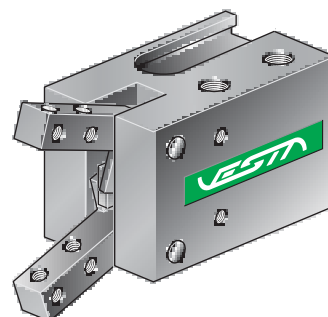

A	B	B1	C	D	E	F	G	H	I	ØJ	K	L	M	N	O	P	Q	R	S	T	U	ØV	ØY	Z	W
35	25	3,95	59	28	M4x0,7	5,2	11,5	4	14,5	M4x0,7	19,5	10	4	8	37	18	41,3	20	8	4,5	3,5	M3x0,5	M4x0,7	6,2	M5x0,8

Weight / Peso : 175 g

6 bar gripping force at 15 mm. from fingers fulcrum:
Forze di bloccaggio a 6 bar a 15 mm di distanza dal fulcro delle dita:

MHM 20 DE	12 Kg	opening / in apertura	10 Kg	closing / in chiusura
MHM 20 SE NC	8,5 Kg	opening / in apertura		
MHM 20 SE NA	7,5 Kg	closing / in chiusura		

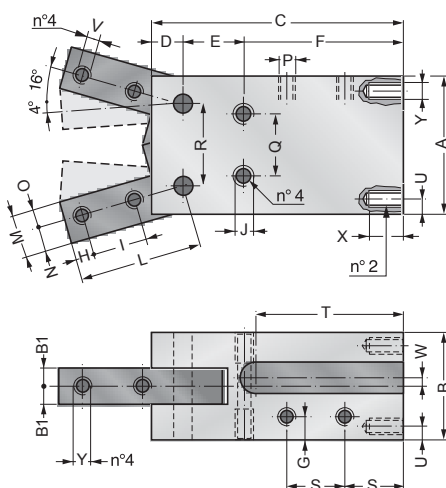

MAGNETIC GRIPPER Ø32
UNITA' MAGNETICA Ø32

MHM 32

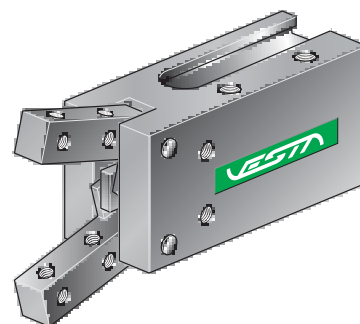

A	B	B1	C	D	E	F	G	H	I	ØJ	L	M	N	O	P	Q	R	S	T	U	ØV	W	X	ØY
45	35	5,95	82	10,2	20	51,8	7	6	20	M6x1 (10mm)	45	14	8	6	M5x0,8	20	28	19	48	5	M5x0,8	2	11	M6x1

Weight / Peso : 490 g

6 bar gripping force at 15 mm. from fingers fulcrum:
Forze di bloccaggio a 6 bar a 15 mm di distanza dal fulcro delle dita:

MHM 32 DE	24 Kg	opening / in apertura	22 Kg	closing / in chiusura
MHM 32 SE NC	19,5 Kg	opening / in apertura		
MHM 32 SE NA	16,5 Kg	closing / in chiusura		



MHM 50 MAGNETIC GRIPPER Ø50
UNITÀ MAGNETICA Ø50

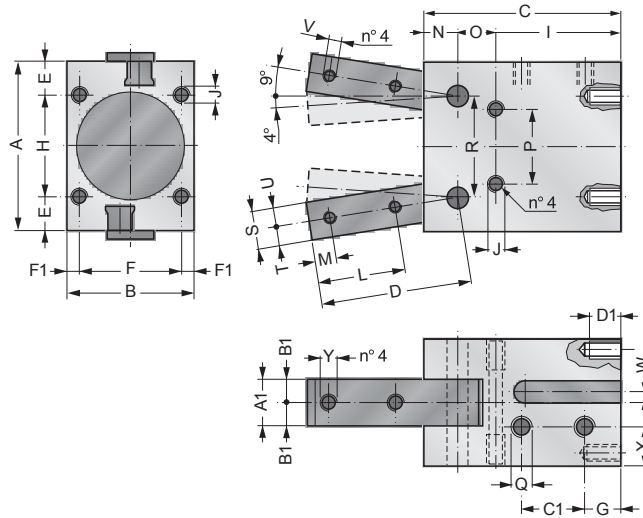
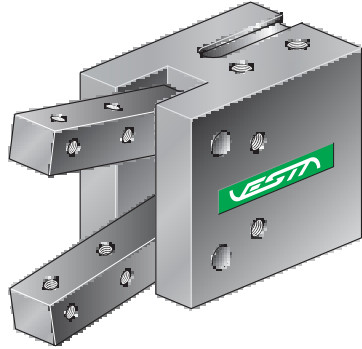

A	A1	B	B1	C	C1	D	D1	E	F	F1	G	H	I	ØJ	L	M	N	O	P	Q	R	S	T	U	ØV	W	X	ØY
80	22	60	11	100	24	71	15	16	48	6	21	48	61	M8x1,25	40	10	18	21	35	G1/8"	48	18	10	8	M6x1	4	17	M8x1,25

Weight / Peso : 1680 g

6 bar gripping force at 30 mm. from fingers fulcrum:
Forze di bloccaggio a 6 bar a 30 mm di distanza dal fulcro delle dita:

MHM 50 DE	60 Kg	opening / in apertura	52 Kg	closing / in chiusura
MHM 50 SE NC	49 Kg	opening / in apertura		
MHM 50 SE NA	46 Kg	closing / in chiusura		

MAGNETIC SWITCHES FOR MHM .. GRIPPERS / FINECORSA PER MANI DI PRESA SERIE MHM ..

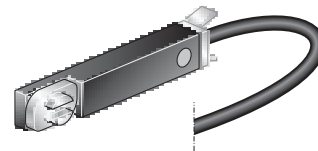
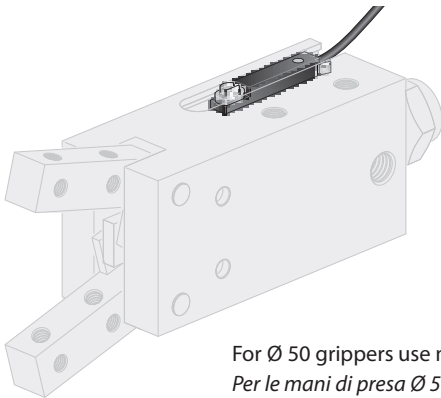

For magnetic switches features see: - Caratteristiche finecorsa magnetici vedi:

VNCR2, VNPR2, VNCE3, VNPE3.

Pag. A-19

For Ø 50 grippers use magnetic switches FTV 306 V (see page A-38).
Per le mani di presa Ø 50 mm usare sensori FTV 306 V (vedere pag. A-38).

..... - SG SEALS KIT
KIT GUARNIZIONI DI RICAMBIO

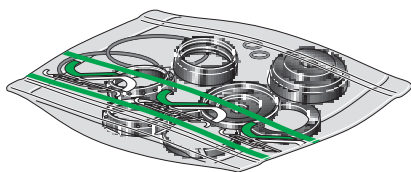

Seals kit code = **Gripper code + Bore + - SG:**
(The kit includes all seals).

Codice del kit = **Codice della mano di presa + Alesaggio + - SG:**
(Il kit comprende tutte le guarnizioni necessarie).

Example / Esempio: **MHM 32 - SG**